

# ROTAMAC

## ROTAMAC SEW Series Sewage Pumps (Non-Clog Impeller)

---



# ROTAMAC

## INTRODUCTION

ROTAMAG SEW range of pumps has been designed to handle unscreened raw sewage. The range incorporates our knowledge and experience of successful pumping of liquids containing solids and waste material throughout the world. The pumps handle flow rates up to 4,000 m<sup>3</sup>/hr and heads up to 100 m. For duties beyond this range, we can offer customized pumps to meet your specific pumping needs

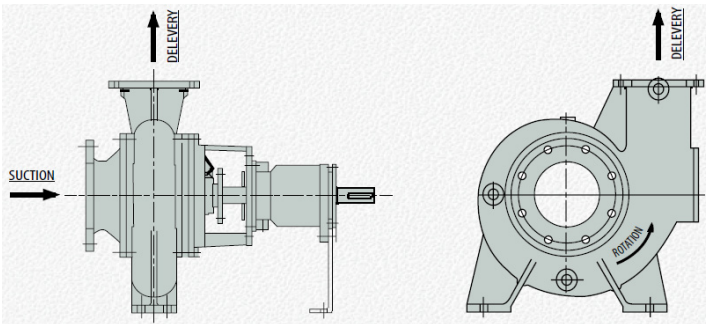

The pumps are available either as horizontal or vertical dry well units. Vertical pumps are offered with direct motor mounted or cardan shaft options. Impellers are of open shrouded design with supplementary vanes at the back and front to minimize the chances of ragging and to eliminate the ingress of abrasive materials to the stuffing box area. They have been designed with the minimum number of vanes compatible with good hydraulic performance to ensure that the maximum sizes of solids can be handled. To further reduce the possibility of ragging, eye velocities have been kept deliberately low.



Three Vane Impeller



Two Vane Impeller

The stuffing box can be provided both with packed glands and mechanical seals. The stuffing box is configured to ensure maximum sleeve life, thus reducing the cost of maintenance. The solid volute casing is protected by renewable wear rings at the front and the back of the impeller. To facilitate cleaning, both the casing and suction branch are provided with easily removable hand hole covers. The vertical selection is available with the motor mounted directly on the pump or with it at a higher floor level in which case it is connected through intermediate cardan shafting to the pump. Depending upon the length involved, this shafting may have intermediate bearings of the plummer block style.

## PUMP DESIGN AND TESTING STANDARDS

- Balanced impeller according to ISO1940 grade G6.3, ensures smooth operation.
- Full compliance with ISO9908 / ISO5199 shaft run-out and ISO10816-7 vibration requirement.
- Performance test of pumps based on ISO9906 and ANSI/HI14.6 grade 2B

## APPLICATIONS

SEW range have been designed to meet the most demanding hydraulic coverage requirements and for all types of liquid, making it the ideal range for challenging pumping operations :

- Sewage treatment plant
- Water containing sludge
- Raw water
- Unscreened raw sewage

## WORKING CONDITION

- Liquid pumping temperature up to 95 °C
- Maximum suction pressure: 5 barg
- Maximum permissible pressure: 12/16 barg
- Maximum solid passage: up to 130 mm
- Flow rate: up to 4,000 m<sup>3</sup>/h
- TDH: up to 100 m
- Speed: 1500 / 1000 / 750 rpm for 50 Hz

## MATERIAL AND CONSTRUCTION

- Pump casing & impeller: cast iron, ductile cast iron, carbon steel, bronze, 304 / 316 / duplex stainless steel, Ni resist
- Shaft: high tensile steel, stainless steel
- Shaft seal: mechanical seal, gland packing
- Flange Nozzles: DIN PN10/16 or drilled to ASME B16.5 / JIS standard

Other corrosion resistant material available on request.

The pump is driven by a standard IEC foot mount motor or diesel engine. The power is transmitted through a standard or spacer coupling.

The baseplate is fabricated from steel, drill and tap bases, secure pump and motor to base, made more rigid and pre-alignment before delivery. T-frame baseplates also available on request.

# SEW Series, Sewage Pumps

## PUMP SELECTION CHARTS

Curves on this page are for guidance only.  
Refer to the performance curves on each model.

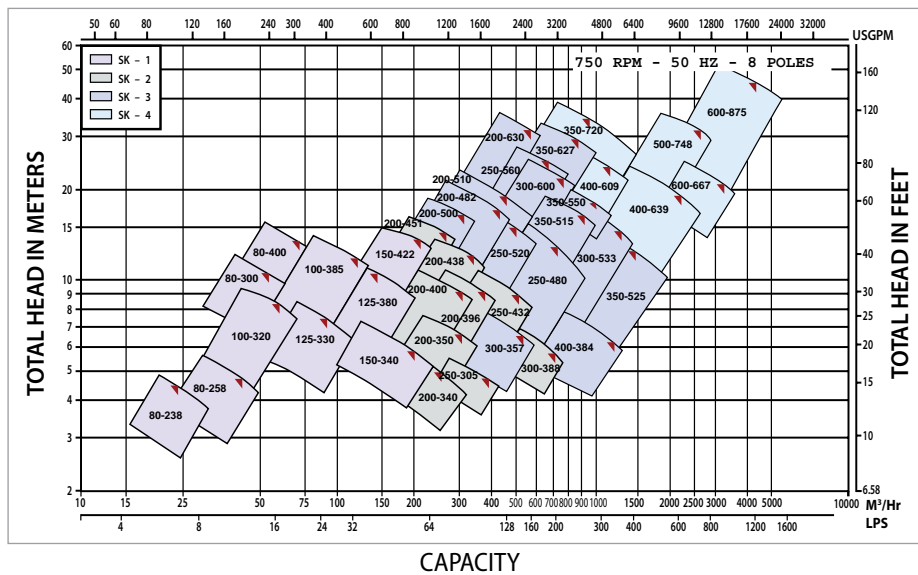
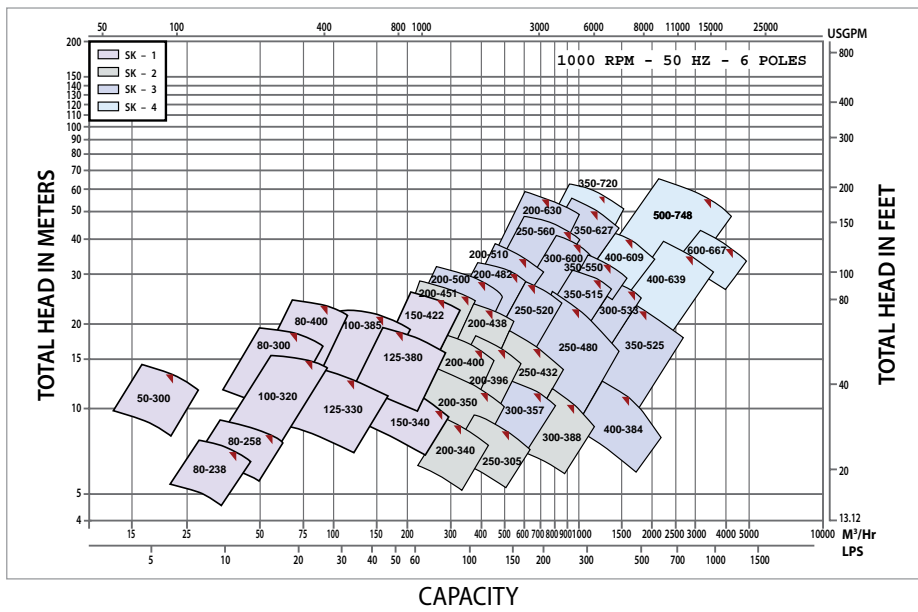
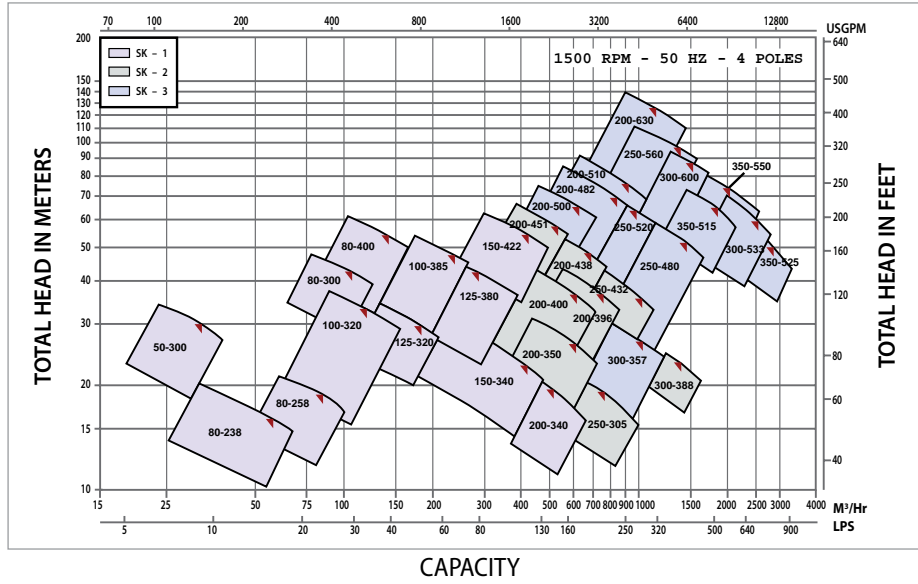

## PUMP SECTIONAL DRAWING AND PARTS LIST - HORIZONTAL DRY PIT

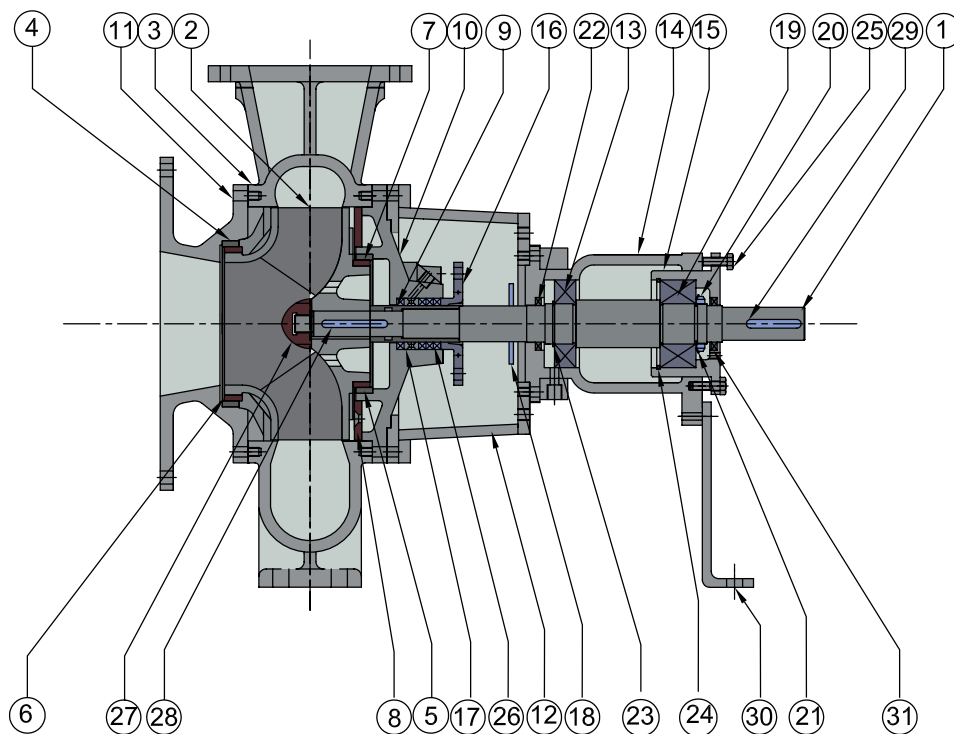

No.	Part Description	Part no.
1	Shaft	101
2	Impeller	102M
3	Casing	183M
4	Front Casing Wear Ring	220-A
5	Back Casing Wear Ring	222-B
6	Front Impeller Wear Ring	231-A
7	Back Impeller Wear Ring	232-B
8	Back Wear Plate	330
9	Shaft Sleeve	150
10	Stuffing Box Cover	323
11	Suction Cover	322
12	Bearing Pedestal	320
13	Inboard Bearing	214
14	Bearing Housing	256
15	Bearing Carrier	318
16	Split Gland	144

17	Lantern Ring	149
18	Water Thrower	145
19	Outboard Bearing	215
20	Lock Nut	141
21	Lock Washer	142
22	Oil Seal for Bearing Housing	174
23	Circlip for Inboard Bearing	337
24	Circlip for Outboard Bearing	336
25	Adjusting Screw	-
26	Gland Packing	143
27	Impeller Nose Cap	218
28	Impeller Key	180
29	Coupling Key	138
30	Support Foot	217
31	Oil Seal for Bearing Carrier	325

# SEW Series, Sewage Pumps

## PUMP SECTIONAL DRAWING AND PARTS LIST - VERTICAL DRY PIT

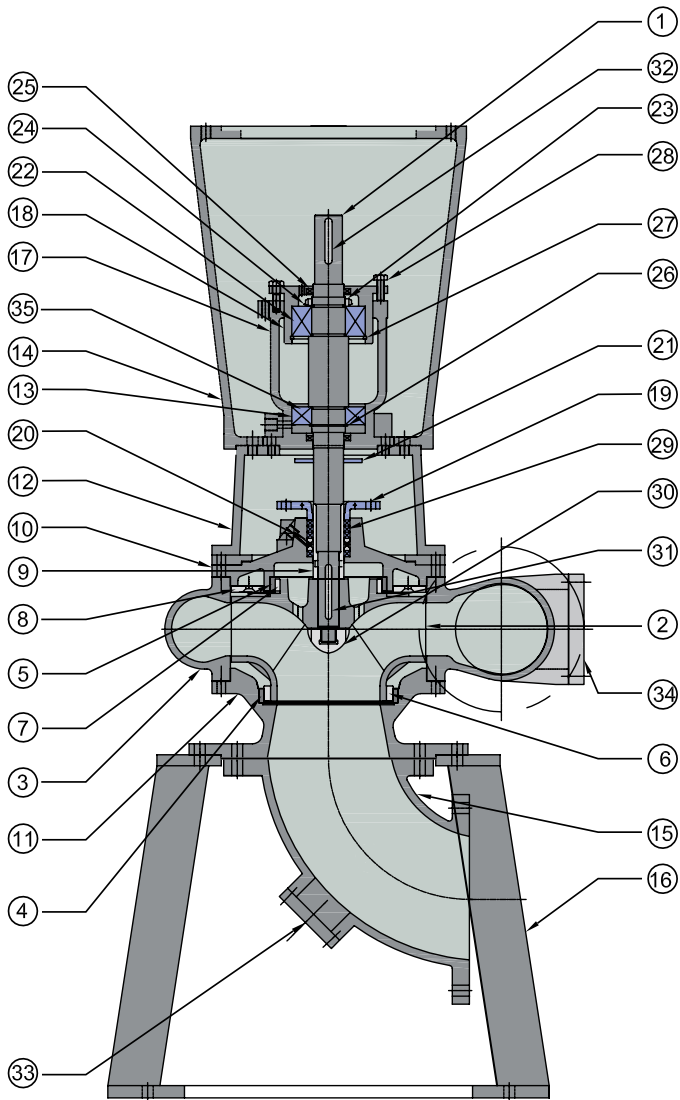

No.	Part Description	Part no.
1	Shaft	177
2	Impeller	102M
3	Casing	178M
4	Front Casing Wear Ring	220-A
5	Back Casing Wear Ring	222-B
6	Front Impeller Wear Ring	231-A
7	Back Impeller Wear Ring	232-B
8	Back Wear Plate	330
9	Shaft Sleeve	150
10	Stuffing Box Cover	323
11	Suction Bend Cover	322
12	Bearing Pedestal	320
13	Inboard Bearing	162
14	Motor Stool	172
15	Suction Bend	321
16	Pump Stool	171
17	Bearing Housing	317
18	Bearing Carrier	318
19	Split Gland	336
20	Lantern Ring	149
21	Water Thrower	169
22	Outboard Bearing	195
23	Lock Nut	163
24	Lock Washer	164
25	Oil Seal for Bearing Housing	174
26	Circlip for Inboard Bearing	337
27	Circlip for Outboard Bearing	336
28	Adjusting Screw	-
29	Gland Packing	143
30	Impeller Nose Cap	218
31	Impeller Key	180
32	Coupling Key	138
33	Suction Bend Hand Hole Cover	327
34	Casing Hand Hole Cover	328
35	Oil Seal for Bearing Carrier	325

# ROTAMAC

- Standardized End Suction Pumps  
EN733/DIN24255, ISO2858/ISO5199  
ASME B73.1, API610
- Split Casing Double Suction Pumps
- Solid Handling Pumps  
Slurry/Vortex/Semi-open/Open/Non clog
- High Pressure Multi-Stage Pumps
- Self-Priming Pumps
- Submersible Pumps
- Close Coupled Pumps
- Vertical Multi-Stage / Immersible Pumps
- Vertical Sump Pumps
- Vertical Turbine Pumps
- Mixed / Axial Flow Pumps
- Liquid Ring Vacuum Pumps
- Chemical Process Plastic Pumps
- Fire Fighting Pump Packages (NFPA20)
- Booster Pump Packages
- Trailer Mounted Pumps

436 Soi On-Nuch 39, Sukhumvit Rd.,  
Suanluang, Bangkok 10250 - Thailand

T : +66 2721 3860  
F : +66 2721 3869  
E : sales@energytechnology.co.th  
www.energytechnology.co.th

ROTAMAC can help relieve the stresses and reduce the life cycle costs associated with the most important aspects of plant operation.

Dedicated to delivering the highest quality support, ROTAMAC services and solutions integrates hydraulic, mechanical and materials engineering knowledge with creative solutions to improve equipment reliability and system performance, reduce energy consumption and improve the safety and environmental impact of operations.

## Pump Services and Repair



## Capabilities Overview

### Design

- Equipment Selection and Optimization
- Material Selection
- System Design
- System Optimization

### Start-up

- Equipment Installation
- Laser Alignment
- Commissioning and Running test
- Operator Training
- On-site Project Supervision
- On-site Troubleshooting

### Operation and Maintenance

- Equipment Inspection
- Repair & Overhaul
- Advanced Diagnostics
- Service Maintenance Contracts