

# ROTAMAC

ROTAMAC RS, RSR series

Heavy duty slurry pumps in abrasion resistant materials

---

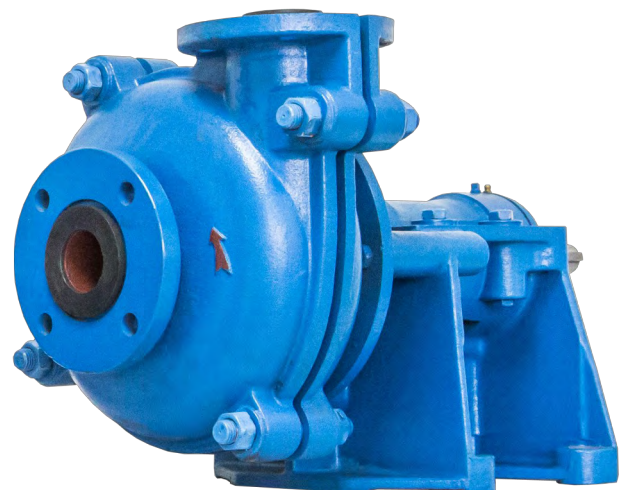

# ROTAMAC

## INTRODUCTION

This data booklet deals with RS, RSR series, horizontal centrifugal slurry pumps, designed for the continuous pumping of highly abrasive, high density slurries.

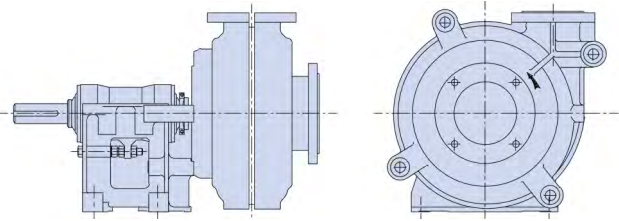

## DESIGN FEATURES

- Casing – Casing halves of ductile iron with external reinforcing ribs provide high operating pressure capabilities and an extra measure of safety.
- Liners – Easily replaceable liners are bolted, not glued, to the casing for positive attachment and ease of maintenance.
- Impeller – Front and rear shrouds have pump out vanes that reduce recirculation and seal contamination. Cast in impeller threads require no inserts or nuts. High efficiency and high head designs are also available.
- Bearing assembly – A large diameter shaft with short overhung minimizes deflection and contributes to long bearing life. Only four through bolts are required to hold the cartridge type housing in the frame. An external impeller adjustment mechanism is provided below the bearing housing for easy adjustment of impeller clearance.
- Shaft sealing – The mechanical type, packing seal type, expeller seal and easily replaceable.
- Shaft sleeve – An easily removable shaft sleeve manufactured in hardened with o-ring seals at both ends protects the shaft from abrasive or corrosive contaminants.

## APPLICATIONS

Heavy duty slurry pumps for a range of mill duties, from dirty water to the most difficult water flushed crusher services.

- Mining & mineral processing
- Sugar processing
- Sand & gravel
- Wet scrubber processing
- Abrasive service applications
- Sludge recirculation

## STANDARDISED

- Pump designed and manufactured in overhung impeller, separately coupled single stage, frame mounted, lined pump.
- Full compliance with ISO9908 / ISO5199 shaft run-out and ISO10816-7 vibration requirement.
- Performance test of pumps based on ISO9906 and ANSI/HI14.6 grade 2B

## WORKING CONDITION

- Flow rate: 2.6 to 5400 m<sup>3</sup>/h
  - TDH: 5 to 65 m
- High head designs are also available.

## MATERIAL AND CONSTRUCTION

- Pump casing: ductile cast iron
- Liners & Impeller: chrome iron ASTM A532, CR29, natural rubber, synthetic elastomer, polyurethane elastomer
- Shaft: carbon steel
- Shaft seal: packing seal, expeller seal, single mechanical seal
- Lubrication: grease

The pump is driven by a standard IEC foot mount motor. The power is transmitted by direct coupling or belt drive. The baseplate is fabricated from steel, drill and tap bases, secure pump and motor to base, made more rigid and pre-alignment before delivery.

## IMPELLER ADVANTAGES

Large, open internal passages designed to reduce internal velocities, maximize solid passages size, maximize wear life and lower operating costs.

Another feature of ROTAMAC slurry pump impellers is the pump out or expelling vanes on the back and front shrouds. These perform the dual function of reducing pressure and keeping solids out of the gaps between the casing and impeller by centrifugal action.



## PUMP SECTIONAL DRAWING AND PARTS LIST

Pump construction is a little different depending on size

### Horizontal Pumps

Item no.	Part name
101	Casing
102	Casing liner
103	Impeller
104	Bearing assembly
105	Shaft sealing
106	Shaft
107	Base

\* Mechanical seal and expeller (dynamic) seal designs are also available.

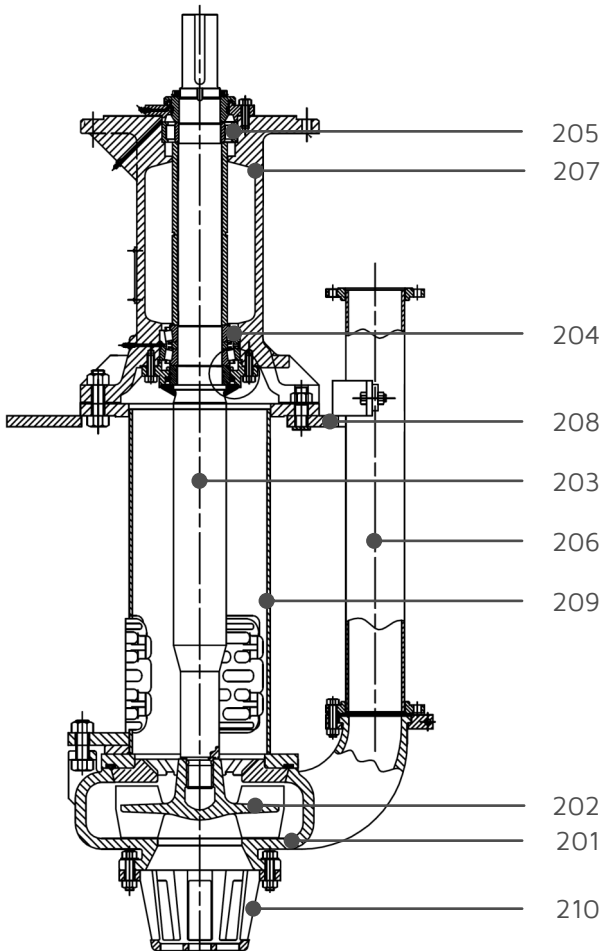
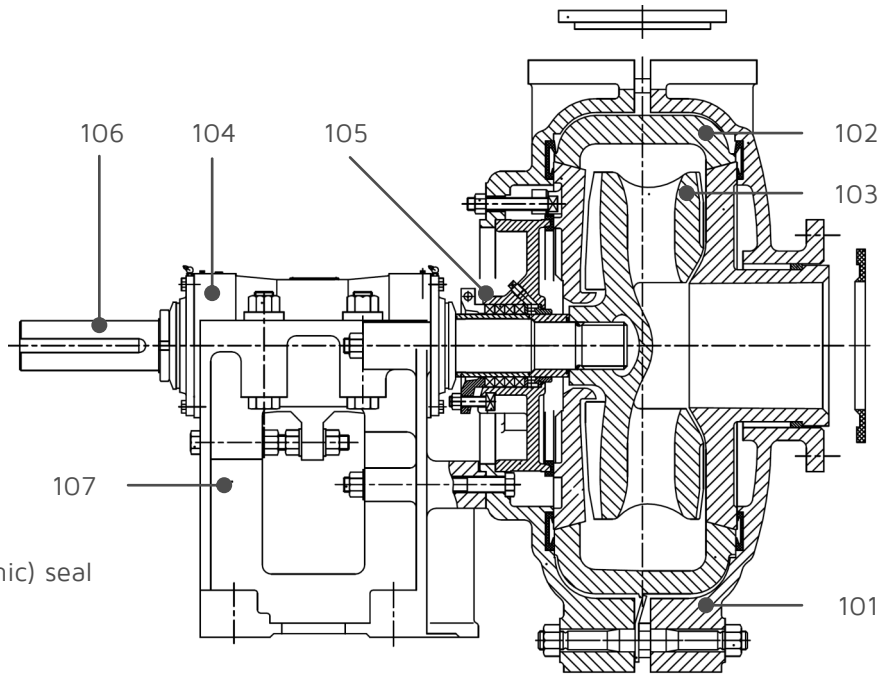

### Vertical Sump Pumps

Item no.	Part name
201	Casing
202	Impeller
203	Shaft
204	Lower bearing
205	Upper bearing
206	Discharge pipe
207	Bearing housing
208	Mounting plate
209	Column
210	Strainer

# RS, RSR Series, Slurry Pumps

## THE COMPLETE MOUNTED PUMP UNIT WITH BASEPLATE AND MOTOR

- Heavy duty construction with through-bolt design provides ease of maintenance and minimal downtime.
- Minimal shaft/impeller overhung reduces shaft deflection and increases packing life.
- Large diameter, slow turning, high efficiency impellers result in maximum wear life and lower operating costs
- Effective expeller prolongs packing life while reducing or eliminating flush water requirement.
- Cartridge-style bearing assembly allows for maintenance in a clean environment without removal of the pump, resulting in reliable operation and prolonged bearing life.
- There are several drive arrangements available for electric motors with direct drive or belt drives, i.e. overhead mounted, reverse overhead and side mounted.



## VERTICAL SUMP PUMP DESIGNED

- The heavy duty cantilever design makes the ROTAMAC RSV, RSRV sump pump ideally suited for heavy continuous handling of abrasive and corrosive liquids and slurries whilst submerged in sumps or pits.
- Large, open internal passages reduce internal velocities maximizing wear life resulting in lower operating costs.
- Available in various standard lengths to suit common sump depths, for deep sumps or where high shaft speeds limit the length of the pump, a suction extension pipe can be fitted to the bottom inlet to extend the depth of the pump by up to 2 meters.
- Less wear, less corrosion, wetted components are available in a wide range of alloys and elastomers, for maximum resistance to wear in virtually any industrial application, including those demanding both abrasion and corrosion resistance and where larger particles or high density slurries are encountered.
- No submerged bearing failures, No shaft sealing problems, No priming required, Less risk of blocking.

## Selection Charts

Curves on this page are for guidance only.  
Refer to the performance curves on each model.

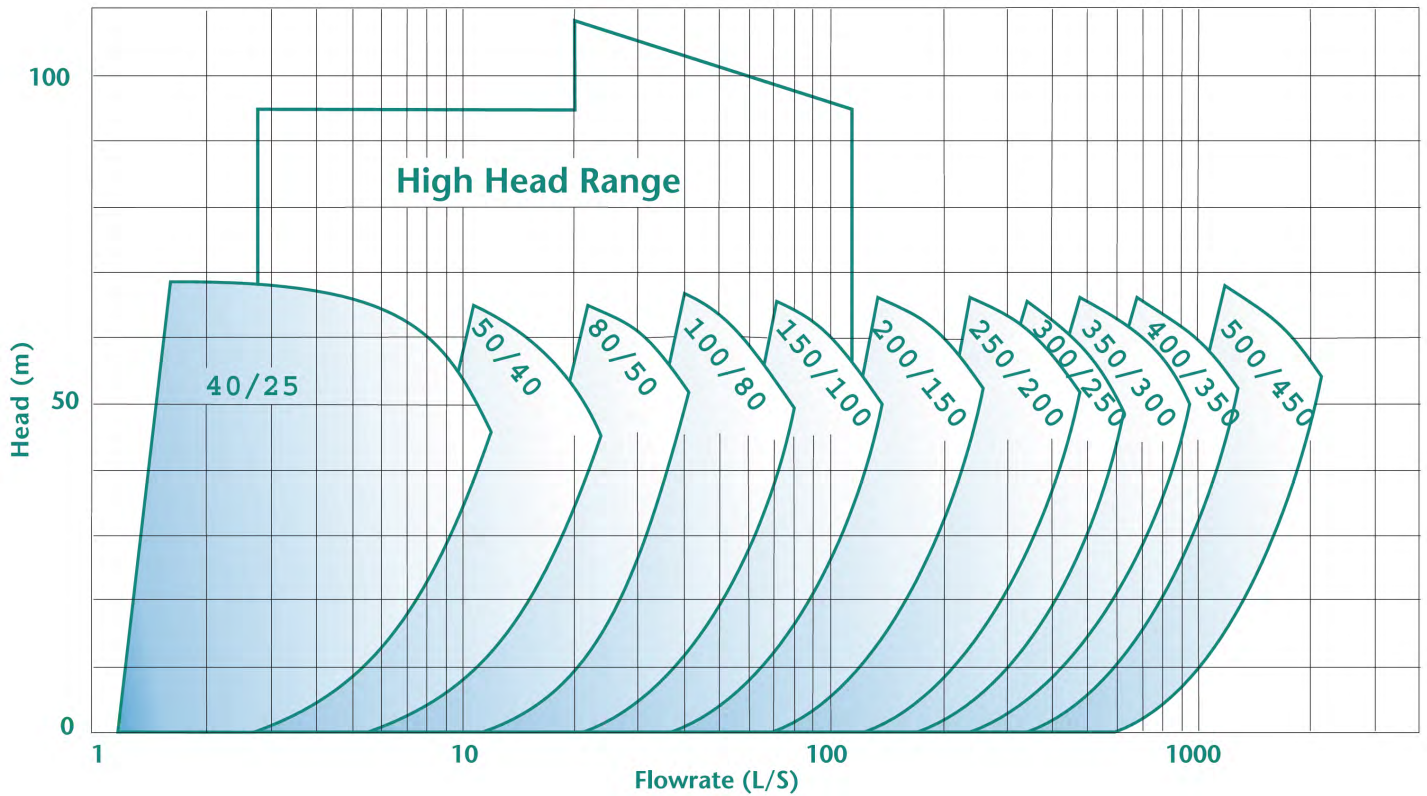

### AVAILABLE MOTOR ARRANGEMENTS

Each application is unique – not only the pumped medium needs to be considered, but the space requirements as well as any other features.

ROTAMAC offers you maximum flexibility. Our engineers and metalworkers will rise to any challenge and develop the very best solution for you. You can see some options already up-and-running here.

ROTAMAC RS, RSR pump designs

- Direct coupled
- Side mounted
- Overhead mounted
- Reverse overhead mounted

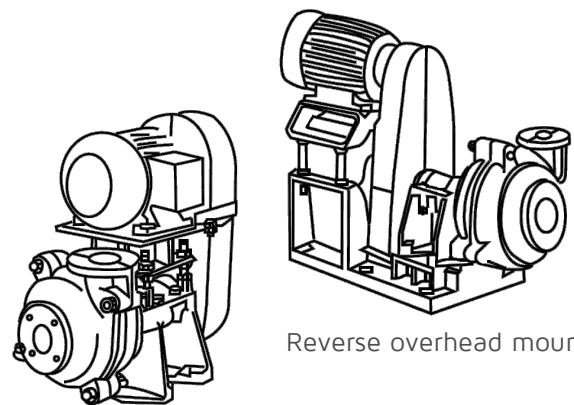

Overhead mounted

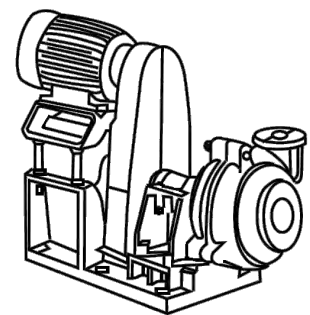

Reverse overhead mounted

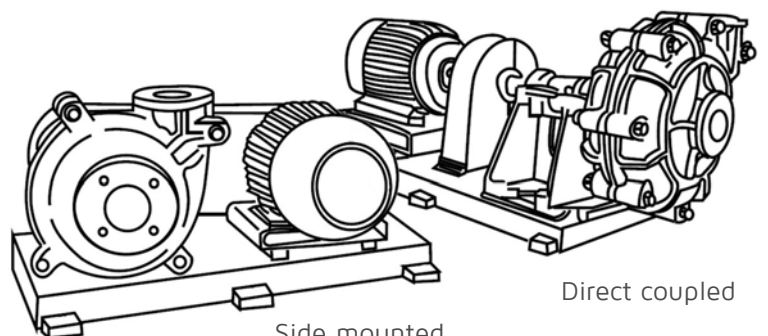

Side mounted

Direct coupled

# ROTAMAC

- Standardized End Suction Pumps  
EN733/DIN24255, ISO2858/ISO5199  
ASME B73.1, API610
- Split Casing Double Suction Pumps
- Solid Handling Pumps  
Slurry/Vortex/Semi-open/Open/Non clog
- High Pressure Multi-Stage Pumps
- Self-Priming Pumps
- Submersible Pumps
- Close Coupled Pumps
- Vertical Multi-Stage / Immersible Pumps
- Vertical Sump Pumps
- Vertical Turbine Pumps
- Mixed / Axial Flow Pumps
- Liquid Ring Vacuum Pumps
- Chemical Process Plastic Pumps
- Fire Fighting Pump Packages (NFPA20)
- Booster Pump Packages
- Trailer Mounted Pumps

436 Soi On-Nuch 39, Sukhumvit Rd.,  
Suanluang, Bangkok 10250 - Thailand

T : +66 2721 3860  
F : +66 2721 3869  
E : sales@energytechnology.co.th  
www.energytechnology.co.th

ROTAMAC can help relieve the stresses and reduce the life cycle costs associated with the most important aspects of plant operation.

Dedicated to delivering the highest quality support, ROTAMAC services and solutions integrates hydraulic, mechanical and materials engineering knowledge with creative solutions to improve equipment reliability and system performance, reduce energy consumption and improve the safety and environmental impact of operations.

## Pump Services and Repair



## Capabilities Overview

### Design

- Equipment Selection and Optimization
- Material Selection
- System Design
- System Optimization

### Start-up

- Equipment Installation
- Laser Alignment
- Commissioning and Running test
- Operator Training
- On-site Project Supervision
- On-site Troubleshooting

### Operation and Maintenance

- Equipment Inspection
- Repair & Overhaul
- Advanced Diagnostics
- Service Maintenance Contracts